

6W SERIES

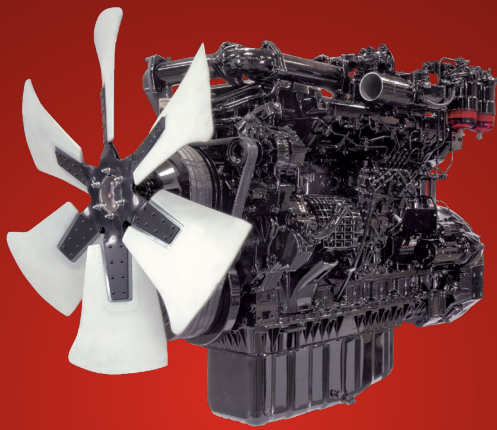

**DEPENDABLE
POWER**

6WG1

Rated Output
512HP (382kW) @ 1800rpm

ISUZU
The power behind it all.™

ENGINE SPECIFICATIONS

6WG1

Displacement	15.7L
Cylinders	6
Cycle	4
Turbo Charger or Charged Air Cooled	Turbo and Charge Air Cooled
Electrical System	Electric self-priming fuel lift pump
Max Torque	2200 Nm (1622.4 lb ft) @ 1450 rpm
5 Year / 5000 Hour Limited Warranty*	Yes
Cooled EGR	Yes
SAE Housing Options	SAE 1 flywheel housing
Gear Case PTO	Optional
Glow Plug Starting Aid	Yes
Aftertreatment	DOC + SCR

*See your authorized Isuzu representative for warranty details.

ENGINE PERFORMANCE CURVES

6WG1

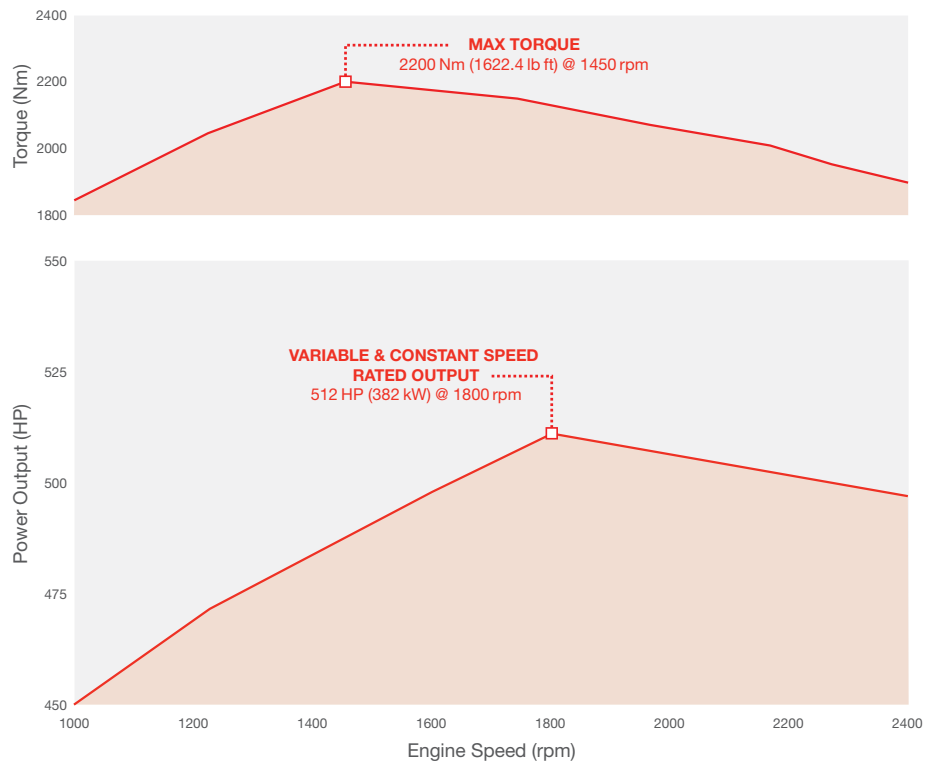



ISUZU REDTECH™

Reliable | Eco-friendly | Durable | Technologically Advanced

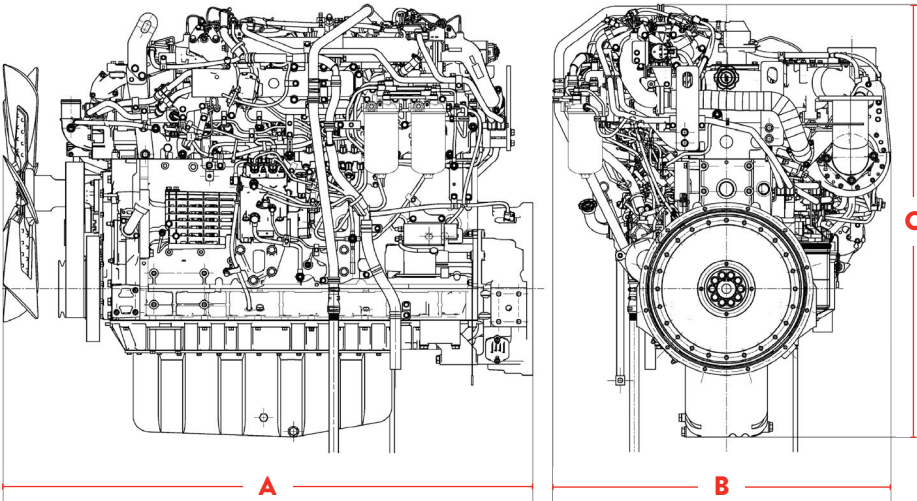

ENGINE DIMENSIONS

6WG1

A - Length 70.4" (1788 mm)

B - Width 40" (1016 mm)

C - Height 52.5" (1333 mm)

Dry Weight 1150 kg (2535.3 lbs)

APPLICATIONS



Agricultural



Forest Machinery



Hydraulic Pump



Air Compressor



General Industrial



Irrigation



Asphalt Paver



Generator



Water Pump



Construction Machinery

CERTIFICATIONS

US | EPA - TIER 4

EU | Stage V¹

STANDARD FEATURES

- Emission Control Device, maintenance free
- DOC & SCR
- Other emission-reducing features, including Cooled EGR and Wastegate Turbocharger
- High pressure Common Rail and Direct Injection
- Electric self-priming fuel lift pump
- Glow plug starting aid
- Dry/replaceable cylinder liners
- 5-year / 5,000-hour warranty²
- 500-hour oil drain & service interval

AVAILABLE OPTIONS

- Side or bottom drain oil pan
- SAE A or B Gear Case PTO
- Cooling packages
- Air cleaners
- Meter board and wire harness
- Engine mounting
- Weather and sound-proofing enclosure
- DEF System



Isuzu Motors America, LLC
 46401 Commerce Center Drive
 Plymouth, Michigan 48170
 Phone: 734.582.9470
 isuzuengines.com

¹ See your authorized Isuzu representative for certified configurations.

² See your authorized Isuzu representative for warranty details.